

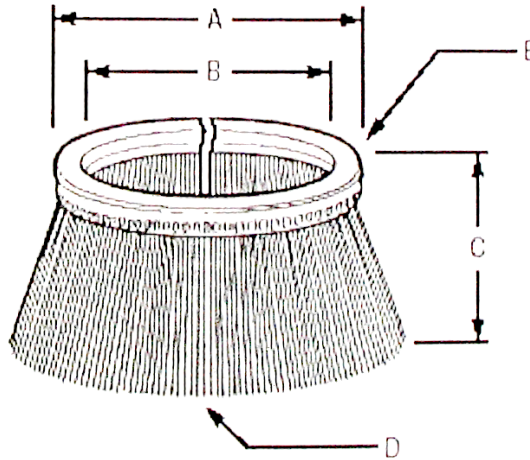

Jenkins Brush Company

P. O. Box 303, Cedar Grove, NJ 07009-0303
 Voice: 1-800-BRUSHES Fax: 1-973-239-8087

DESIGN SHEET FOR METAL CHANNEL STRIP Cup Brushes



A. OUTSIDE DIAMETER _____

B. INSIDE DIAMETER _____

C. OVERALL TRIM _____

D. BRUSH FILLING:
 Type _____
 (nylon, polypropylene, tampico, horse hair, other)

Bristle Diameter _____

Color _____

Crimped or Level Filaments _____

E: METAL CHANNEL SIZE # _____

width x height

#4 3/16 x 3/16

#5 1/4 x 1/4

#7 5/16 x 5/16

#10 7/16 x 7/16

(#4 and #7 are most common)

F: CHANNEL MATERIAL

Galvanized

Stainless Steel

Aluminum

(galv. is most common)

G. WET OR DRY? _____

H. BRISTLE DENSITY

light med heavy

I. QUANTITY PER ORDER _____

J. ANNUAL USAGE _____

K. BRUSH APPLICATION AND/OR COMMENTS

* Please indicate any critical tolerances.